

SPINNER

TC600

Precise Universal Lathe



Mechanical Engineering
Made in Europe

www.spinner.eu.com
sales@spinner.eu.com

Machine Highlights

Ideal for Hard Turning

Available with or without driven tool and Y axis

Small distance between operator and chuck

Compact dimensions for low space requirement

Latest control system:
Siemens 840D-SL or Fanuc 32iT

Siemens Operating panel adjustable
in height and angle

Chip conveyor
as standard

Toolsetter as
standard

Perfect free
chip fall

Large panoramic
window to the
working area

Machining of bars
or integrated
automation with
robotic system



Stable
Compact
Dynamic
Universal
Precise

Powerful tool drive
in the turret

Rigid SPINNER servo turret
with BMT45 or VDI30/VDI40
toolholder

Real Y-axis

Rigid machine
base as a one-
piece casting

CNC tailstock
or subspindle

Modern
motorspindles with
65 mm or 85 mm
bores

Hardened and ground sliding
guideways for best vibration
damping

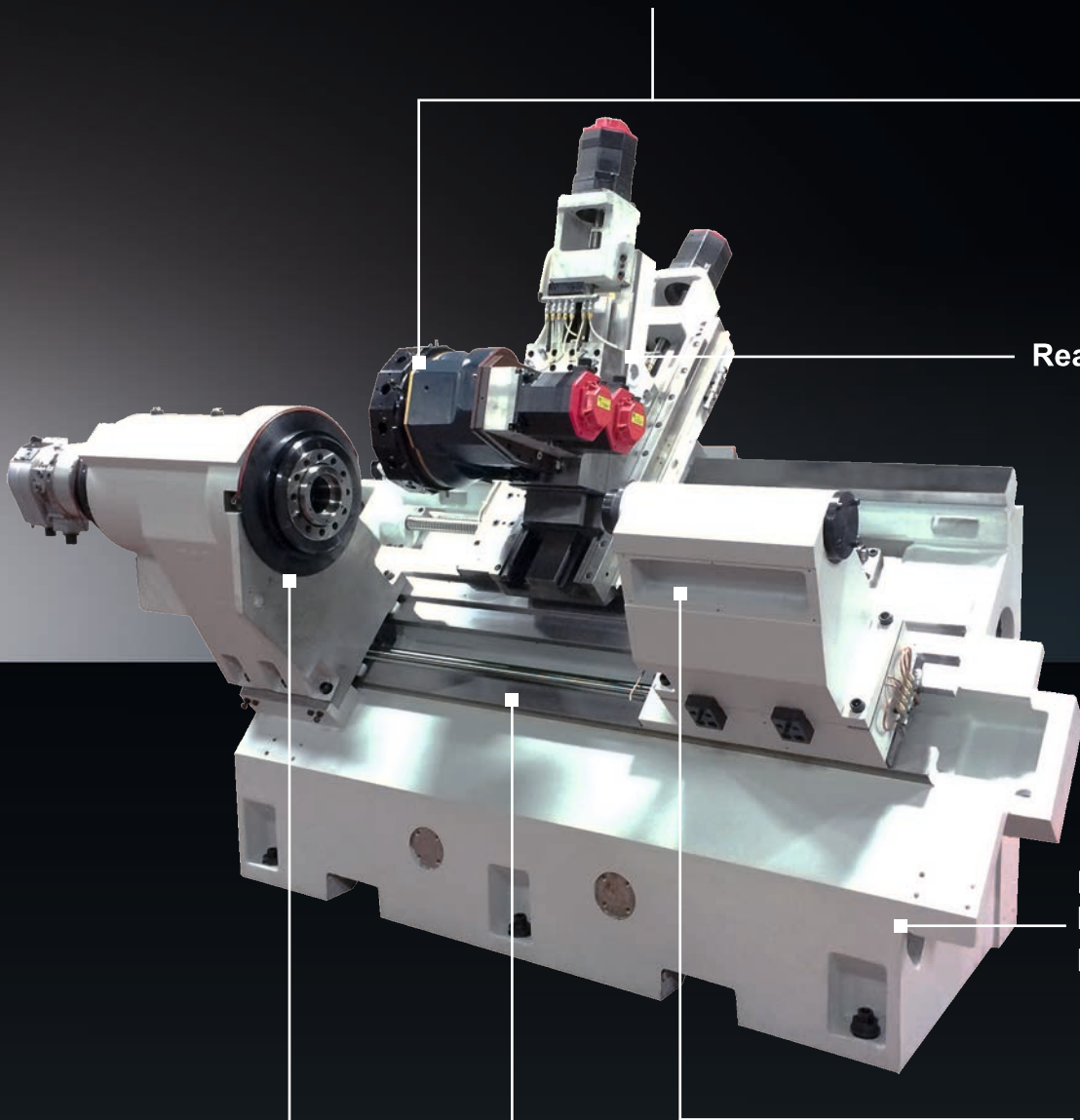

- Rigid SPINNER-turret with high milling performance
- Up to 16 tool stations VDI30 or BMT45
- Up to 12 tool stations VDI40

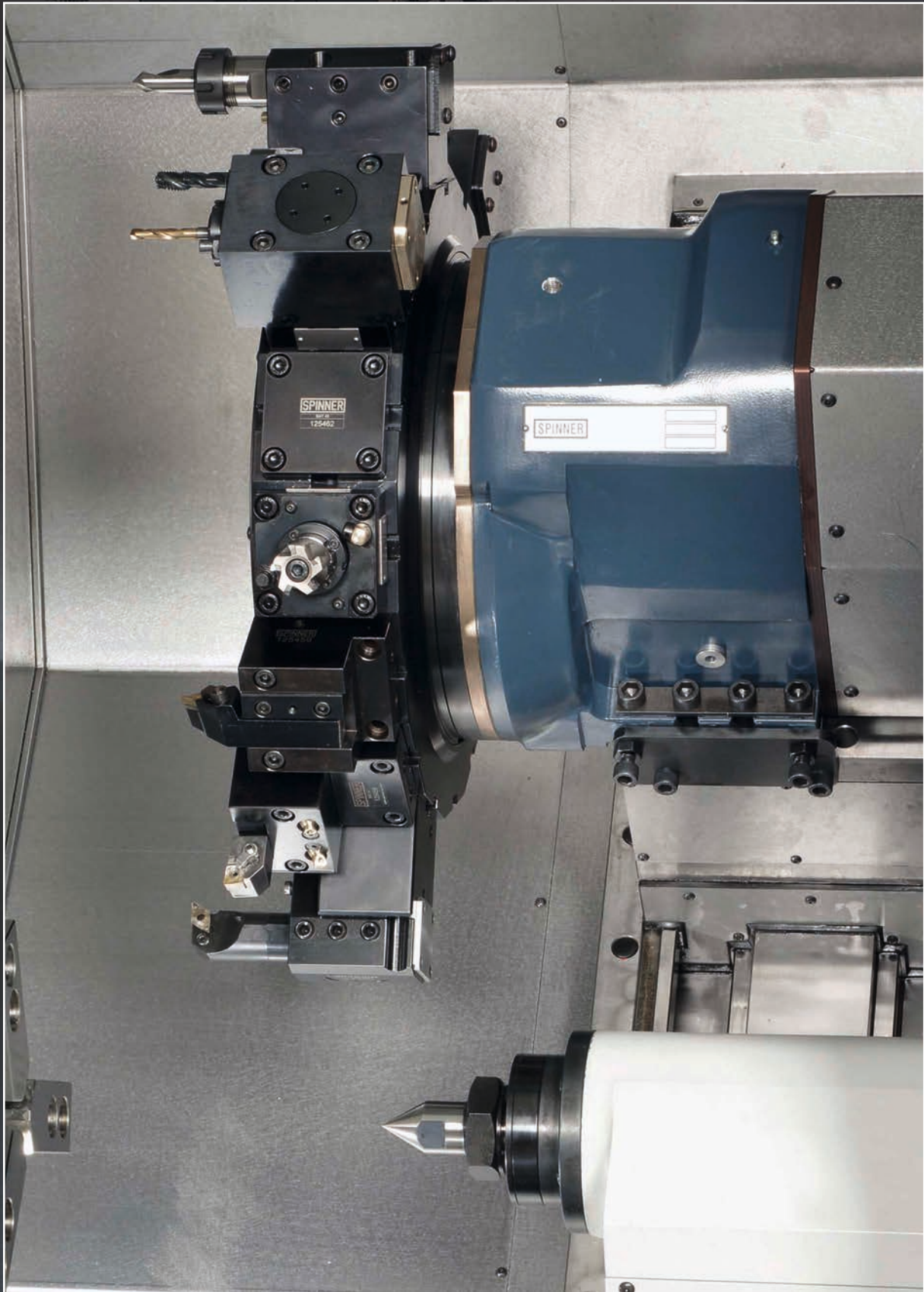
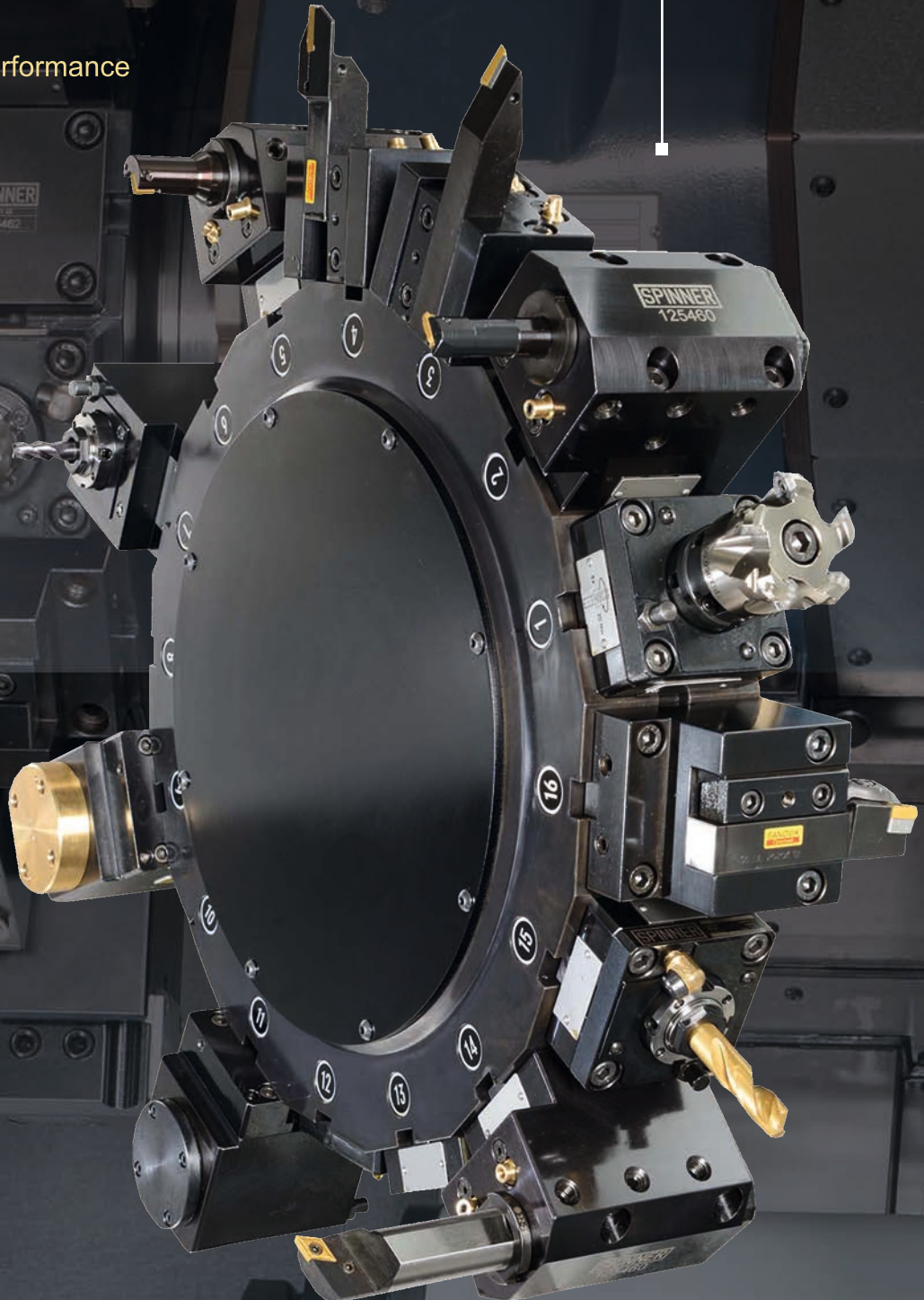

Figure shows turret disc BMT45 and CNC tailstock

•Tool holder BMT45

Your advantages at one glance when using BMT45 tool holders

- High toolholder exchange precision
- No adjustment is required
- High stiffness
- Higher turning and milling performance



•Or toolholder VDI30 / VDI40

Automation solutions

Fully automated production solutions for large-scale production
FROM A SINGLE SOURCE from SPINNER and SPINNER-
Automation



Your advantages at one glance

- Increase in productivity
- Cost reduction
- Optimal processes for your machining requirements
- Everything from one source

Ask us for your solution!

Bar feeding system

SPINNER SERVO short bar feeder for feeding bars up to a maximum of 1500mm



SPINNER SERVO bar loading magazine for feeding bars up to a maximum length of 3,2 metres



Working area	TC600-65	TC600-85
Swing diameter	600 mm	600 mm
Max. turning diameter	~400 mm	~400 mm
Max. turning length	650 mm	650 mm
X1 / Z-axis	275 / 700 mm	275 / 700 mm
Y-axis (option)	+50 / -40 mm	+50 / -40 mm
Axes		
Rapide traverse X / Y / Z	15 / 15 / 24 m/min	15 / 15 / 24 m/min
Spindle 1		
Max. spindle speed	4.000 1/min (option 5.000 rpm)	3.400 1/min (option 4.000 rpm)
Spindle nose	A8/DIN	A8/DIN
Chuck diameter	250 mm	250 mm
Spindle bore	65 mm	85 mm
Performance P_{max}	34 kW	34 kW
Torque M_{max}	325 Nm	325 Nm
Spindle 2		
Max. spindle speed	6.000 rpm	6.000 rpm
Spindle nose	Ø110 mm	Ø110 mm
Chuck diameter	165 mm	165 mm
Spindle bore	42 mm	42 mm
Performance P_{max}	15 kW	15 kW
Torque M_{max}	96 Nm	96 Nm
Turret		
Number of tool stations	16 (VDI30), 12 (VDI40), 16 (BMT45)	16 (VDI30), 12 (VDI40), 16 (BMT45)
Number of driven tools (option)	all	all
Toolholder	VDI30 / VDI40 / BMT45	VDI30 / VDI40 / BMT45
Max. speed of driven tools	6.000 rpm	6.000 rpm
Performance P_{max}	16,5 kW	16,5 kW
Torque M_{max}	35 Nm	35 Nm
General indications		
Dimensions (L x W x H) ¹⁾	2800 x 1750 x 2090 mm	2800 x 1750 x 2090 mm
Weight ²⁾	~5.800 kg	~6.300 kg

1) See floorplan

2) Machine net weight SMCY

Main Spindle TC600-65 4.000 rpm

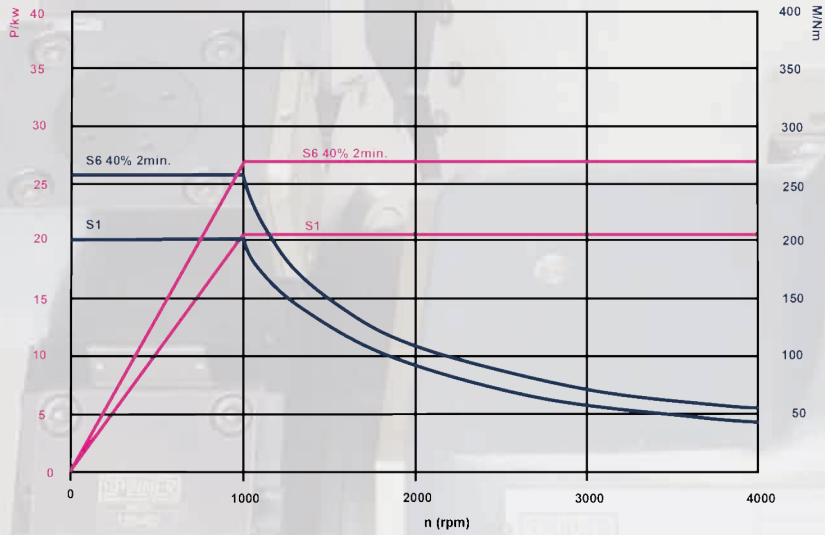

Sub Spindle TC600 6.000 rpm

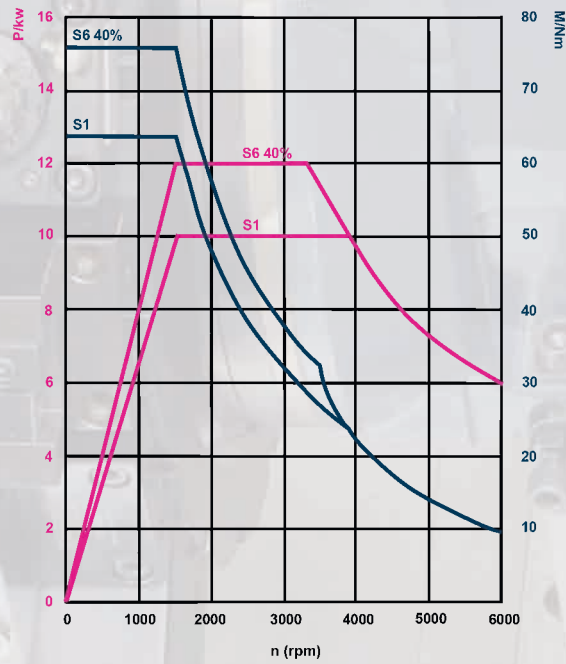

Driven Tool

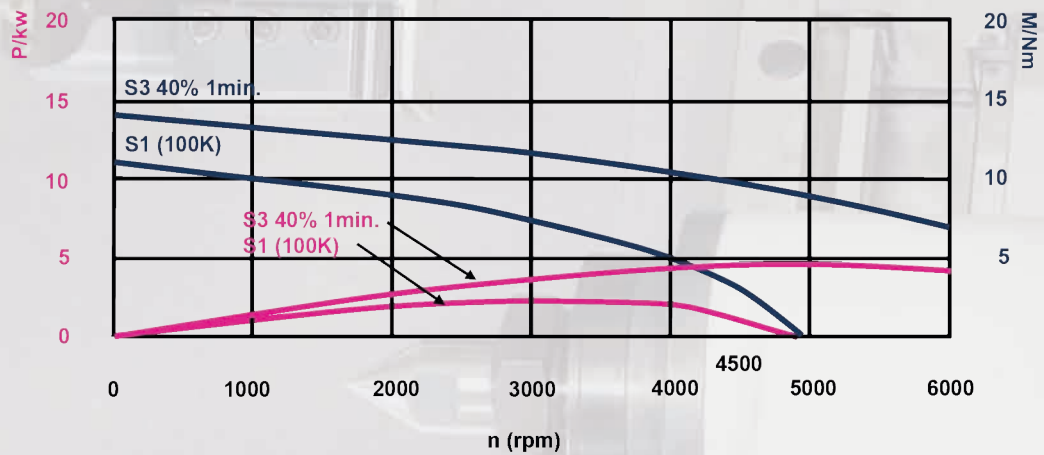

Air nozzle for compressed air on main spindle/sub spindle

Clamping force control by differential pressure for main spindle and/or sub spindle

- Turret disc VDI40 12-position (standard VDI30)
- Turret disc BMT45 16-position
- Toolholder package BMT45
- Toolholder package VDI30/VDI40
- Hard turning package for superfinishing
- Component measurement by touch probe in turret

- Suction unit for coolant mist
- Fire extinguishing system

External tool measurement



High pressure coolant pump 15/50 bar for tools with internal coolant supply

Bar feeder

Automatic door

Siemens 840D-SL
With Spinner 24-inch Touch panel
Fanuc 32iT
With 15-inch screen

Coolant pistol in the working area

Steady rest

Part catcher

Clamping system for the workpiece

Glass scale X1-axis / Z1-axis

Other options on demand

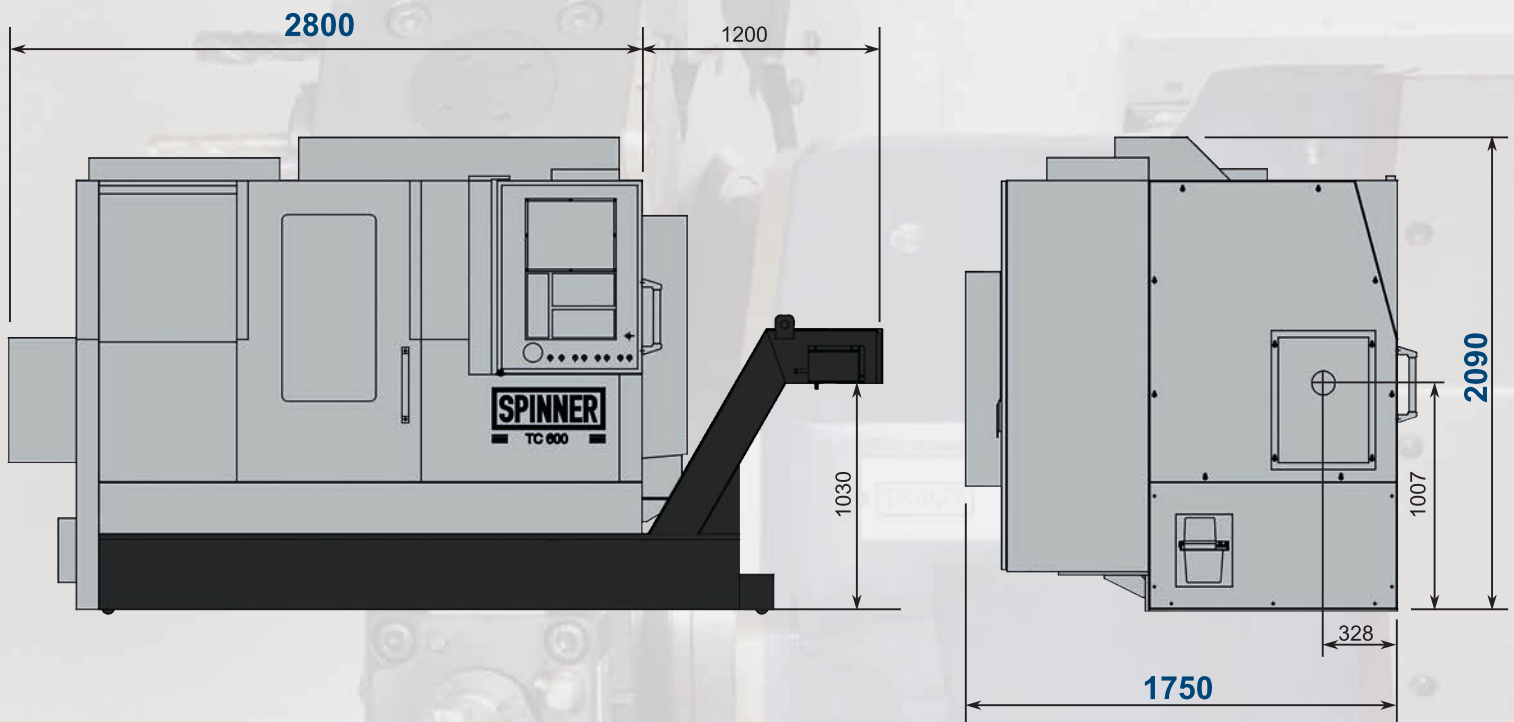

■ Version with standard chip conveyor

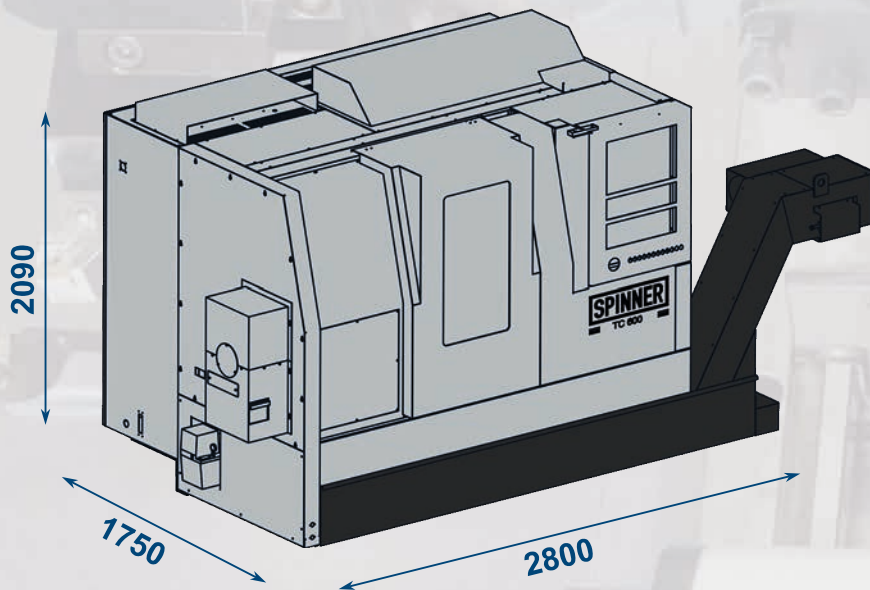

Compact dimensions for low space requirement



Werkzeugmaschinenfabrik GmbH



www.spinner.eu.com

Spinner Machine-Tools are working successfully world wide with many well known clients in more than 60 countries on 6 continents. We have been fortunate enough to attract small component suppliers in addition to well known global groups in all metal machining industries.

We have designed and produced the most modern machine-tools since 1950. More than 20.000 delivered machines demonstrate their high efficiency, precision and reliability, everyday.

Although Spinner is a medium-sized enterprise we produce and sell more than 1.000 CNC machines a year. And the number is increasing every year. Our company combines the know-how of a global player with the flexibility and cost-effective structures of a family owned business.

Place your trust in our products as well and let us know what we can do for you.



Video

SPINNER Werkzeugmaschinenfabrik GmbH

Rudolf-Diesel-Ring 24

82054 Sauerlach

Tel. +49 (0) 8104 803-0

Fax +49 (0) 8104 803-19

sales@spinner.eu.com



Version 12.4.2018 (GB)

Technical changes of specifications and pictures are subject to change without notice - Pictures can include options, accessories