

SPINNER

VC1150 Compact

Performance Machining Centre

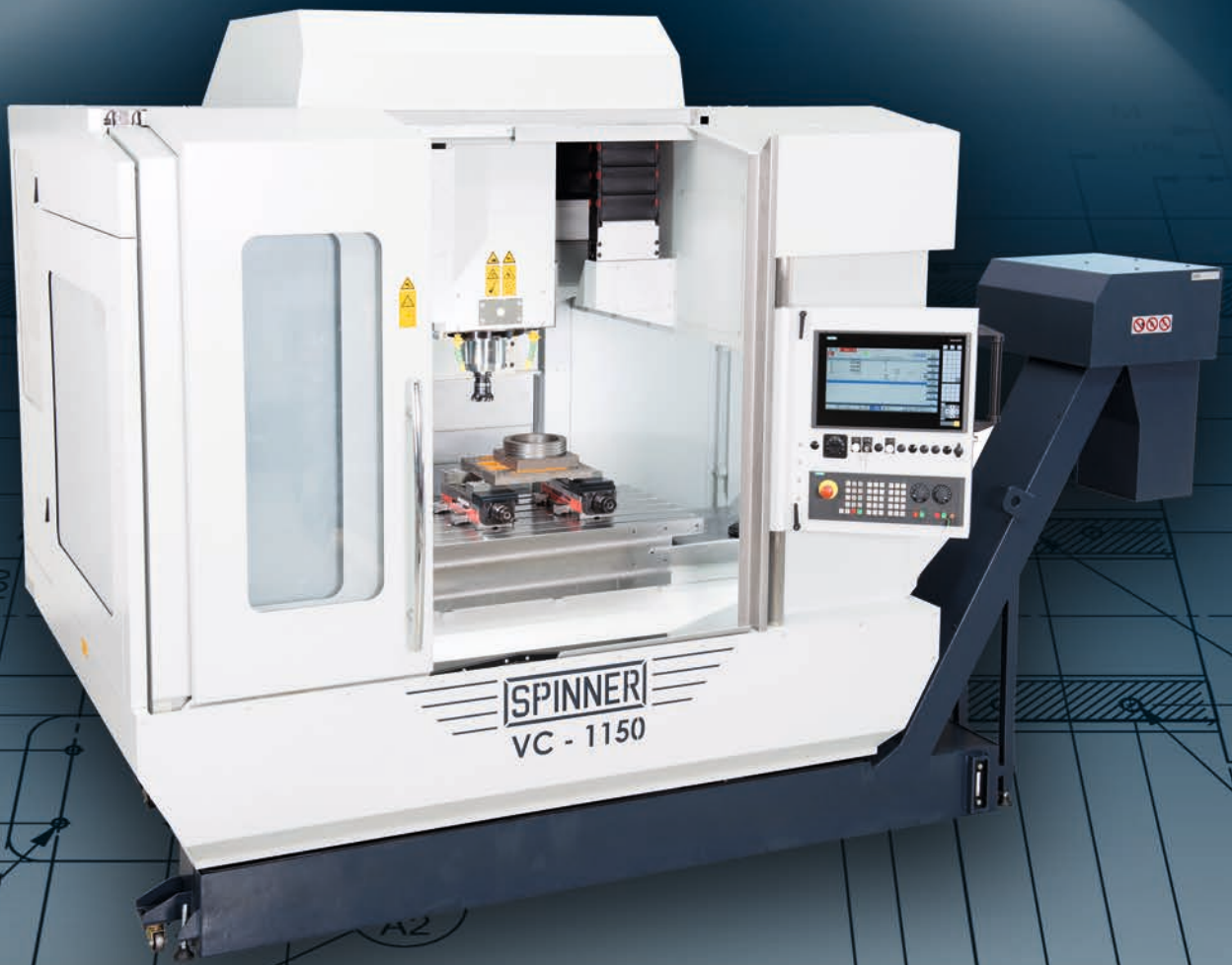

Mechanical Engineering

Made in Germany

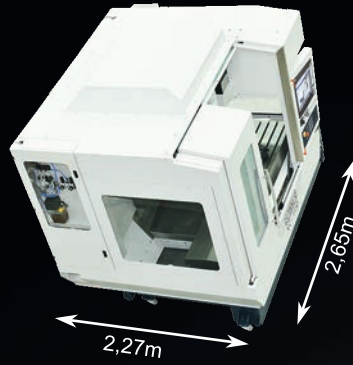
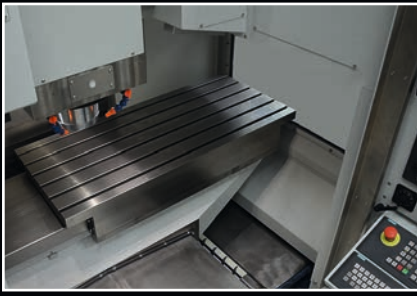

Compact dimensions

By means of an innovative guideway cover concept the required floor space is up to 30% lower than for similar machines of the same working area.

Optimal chip disposal

There are two additional worm conveyors for automatic chip delivery to the chip conveyor at the front of the machine.

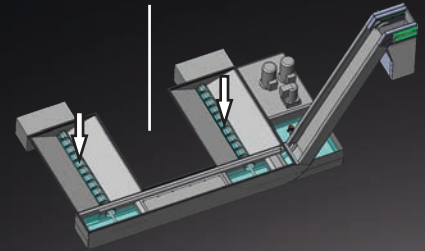

Ergonomic operating panel

The operating panel is height-adjustable and pivotable.



Heidenhain TNC620 Touchscreen

Small distance to the working table

The distance between the operator and the working table is only 200mm. This facilitates the easy loading.



Powerful
Dynamic
Ergonomic
Compact
Made in Germany

Cast structure

A heavy cast structure optimised by the FEM method ensures high rigidity and high cutting performance.

Large tool magazine

32 tools are available

Absolute measuring system as standard

Innovative guideway cover concept

With respectively only one wiper in X/Y for best guideway protection and easy maintenance instead of vulnerable cover elements.

Large ballscrews

All ballscrews are supported on both sides.

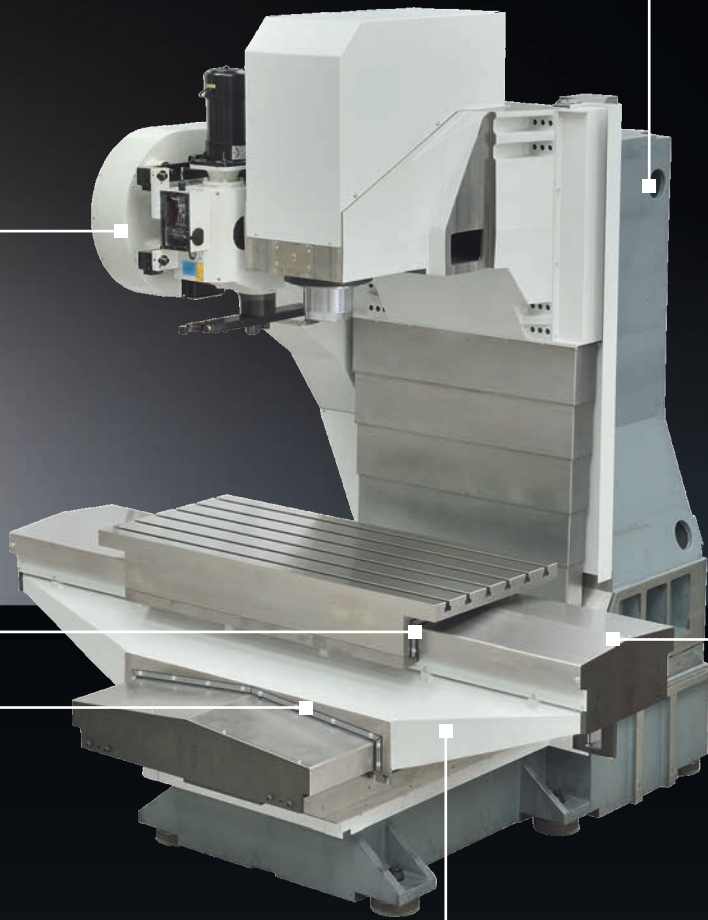

Working area	
X axis	1150 mm
Y axis	620 mm
Z axis	600 mm
Min. distance spindle nose - table	120 mm
Max. distance spindle nose - table	720 mm
Machining table	
Table dimensions	1400 x 620 mm
Max. table load	750 - 1500 kg
T slots	6x 18H7
Axes	
Feed / Rapid traverse	25 m/min; optional 30 m/min ¹⁾
Spindle	
Max. spindle speed	10.000 rpm
Tool taper	SK40 (optional BT40)
Performance	19 kW ¹⁾
Torque	120 Nm ¹⁾
Tool magazine	
Number of tool stations	32 +1
Max. tool diameter	75 mm
In case of free adjacent tool stations	125 mm
Max. tool length	400 mm
Max. tool weight	7 kg
General indications	
Dimensions (L x W x H) *	2650 x 2270 x 2700 mm
Weight	~ 8.300 kg
Control system	Siemens 840D-SL, Heidenhain TNC620 Touchscreen

1) See option "Production package"; 2) See floorplan

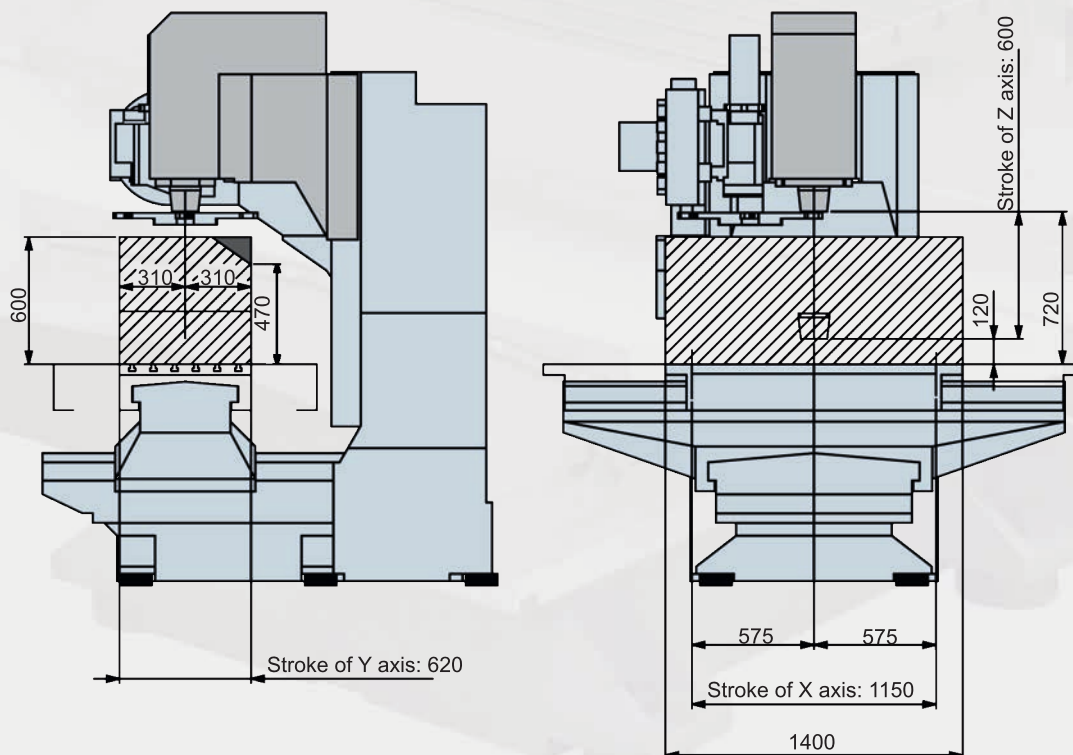

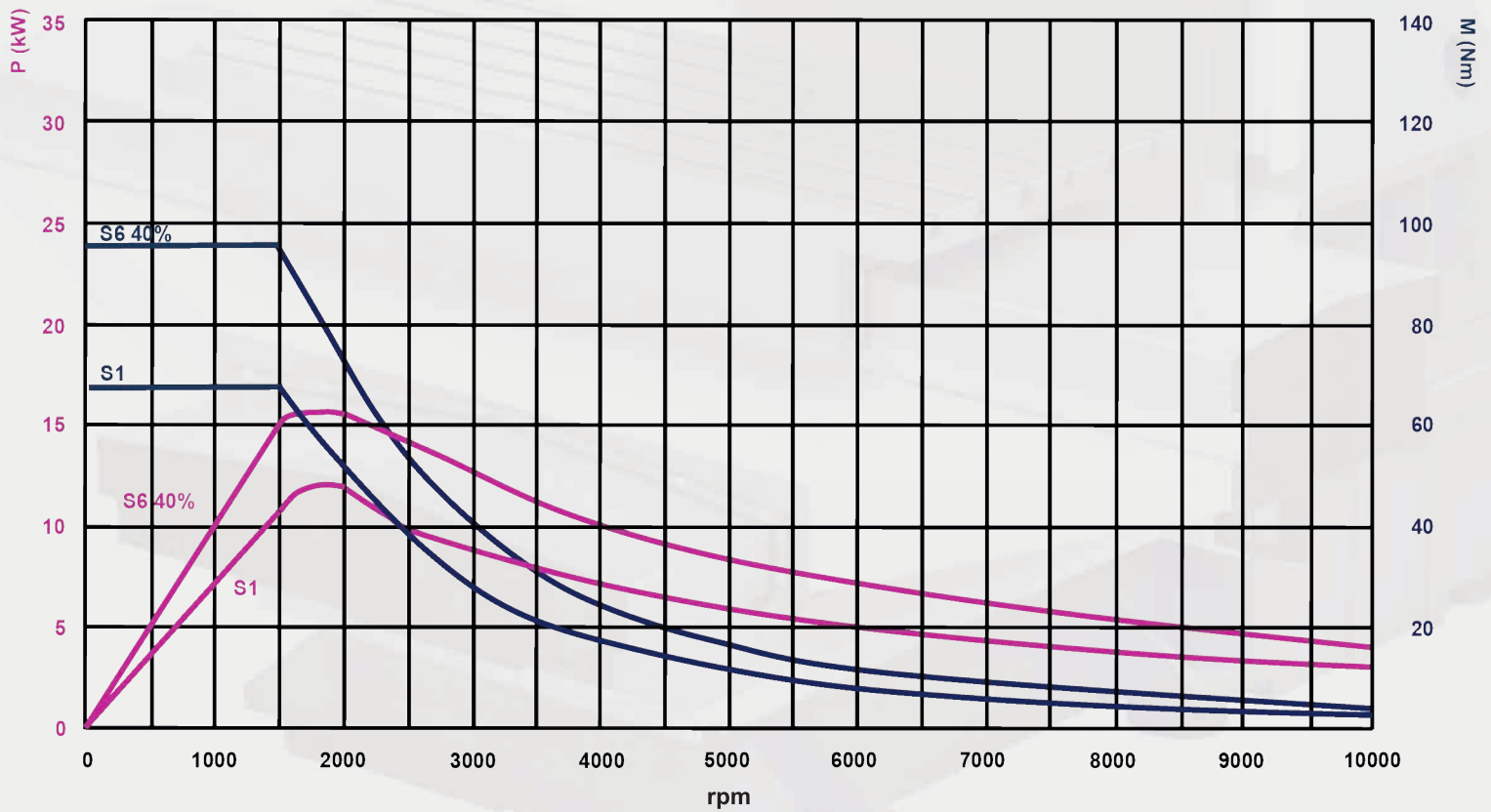
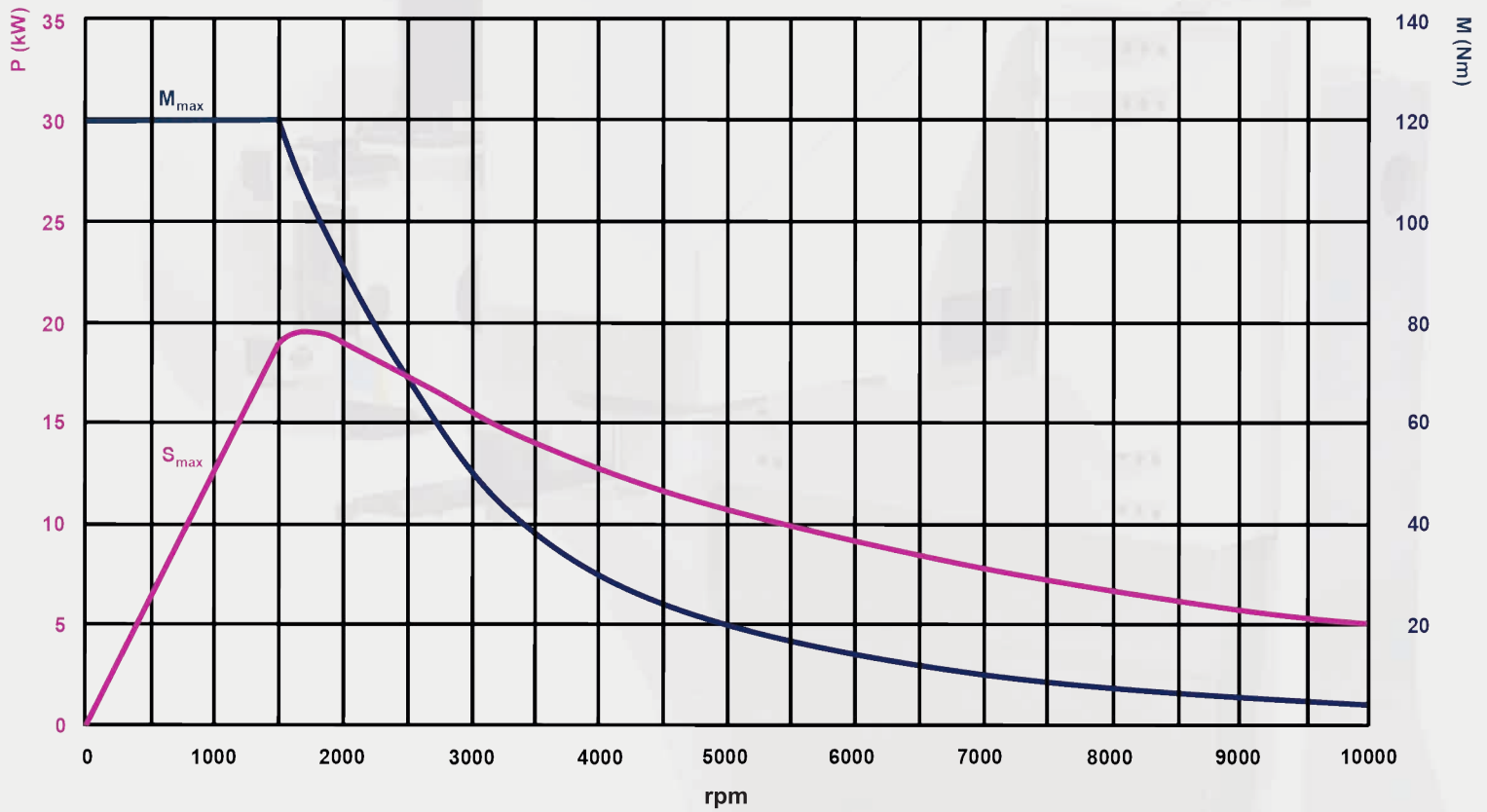

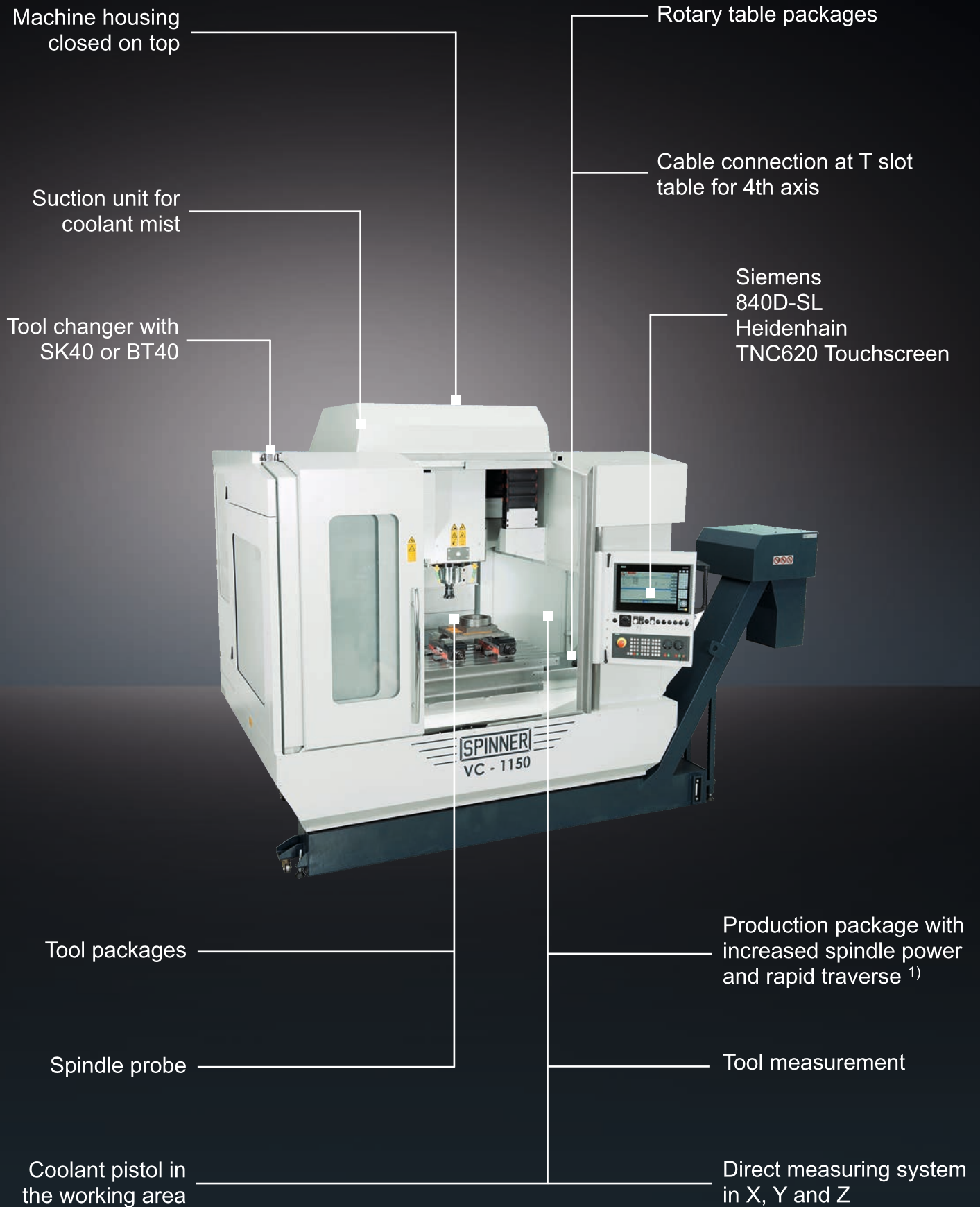

More options on demand
1) See Technical data

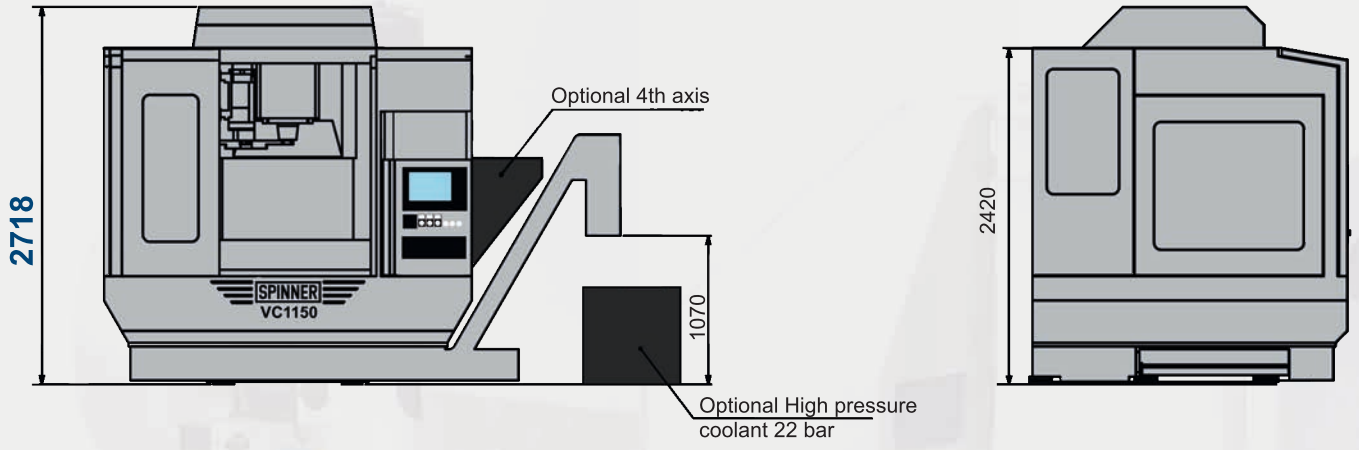

■ Option

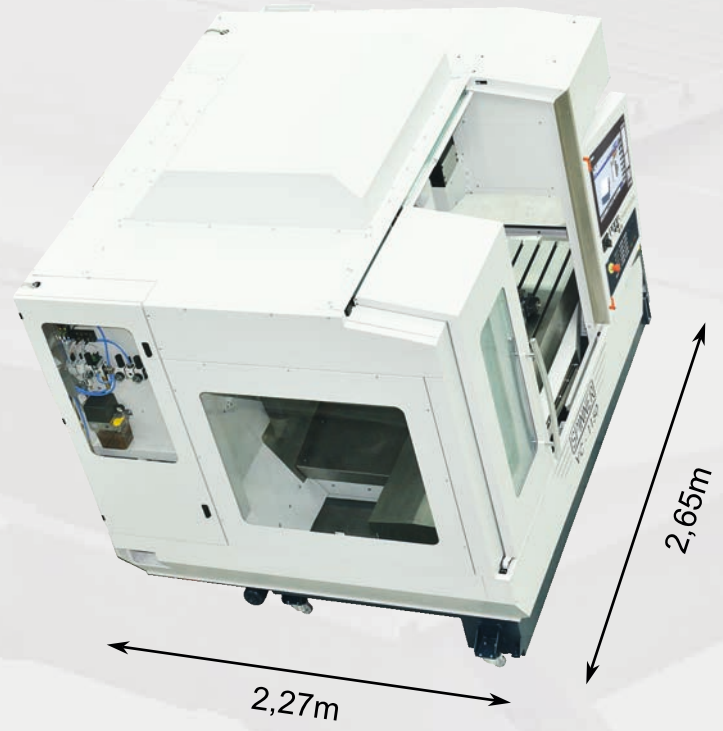
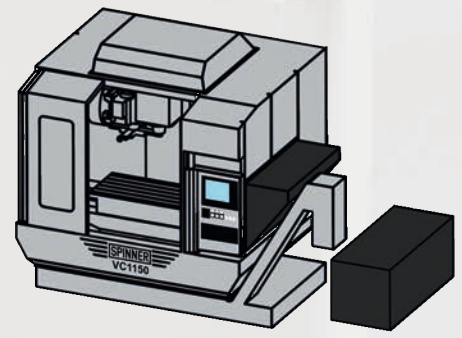
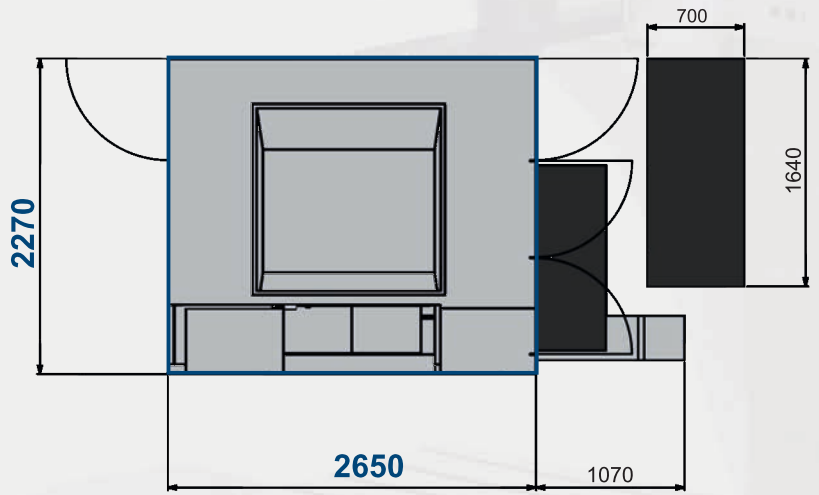



Werkzeugmaschinenfabrik GmbH



Spinner Machine-Tools are working successfully world wide with many well known clients in more than 60 countries on 6 continents. We have been fortunate enough to attract small component suppliers in addition to well known global groups in all metal machining industries.

We have designed and produced the most modern machine-tools since 1950. More than 20.000 delivered machines demonstrate their high efficiency, precision and reliability, everyday.

Although Spinner is a medium-sized enterprise we produce and sell more than 1.000 CNC machines a year. And the number is increasing every year. Our company combines the know-how of a global player with the flexibility and cost-effective structures of a family owned business.

Place your trust in our products as well and let us know what we can do for you.



Video

SPINNER Werkzeugmaschinenfabrik GmbH

Rudolf-Diesel-Ring 24

82054 Sauerlach

Tel. +49 (0) 8104 803-0

Fax +49 (0) 8104 803-19

sales@spinner.eu.com



Verion 29.05.2019

Technical changes of specifications and pictures are subject to change without notice - Pictures can include options, accessories