

# SPINNER

# VC850

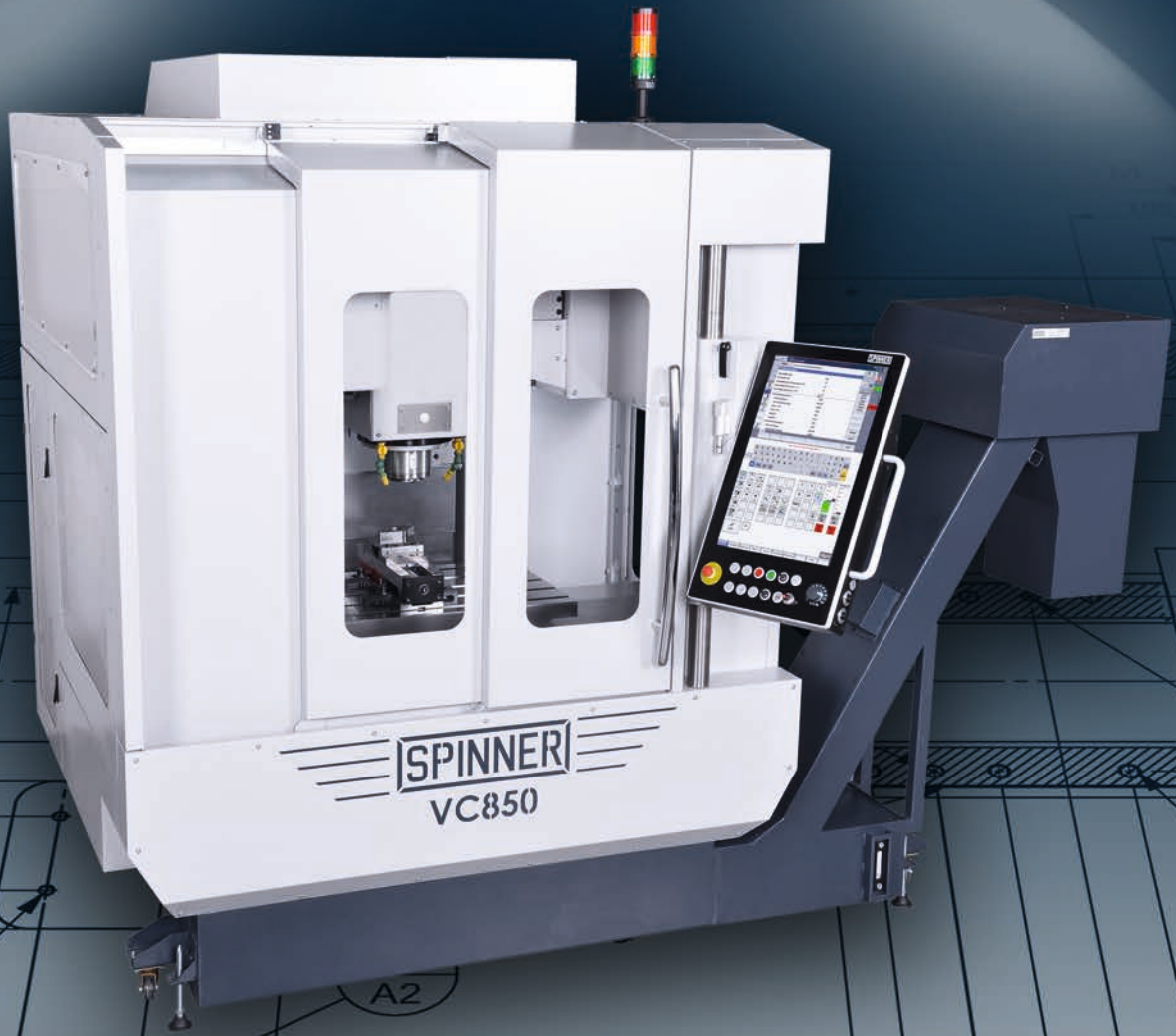

Performance Machining Centre



Mechanical Engineering  
**Made in Europe**

[www.spinner.eu.com](http://www.spinner.eu.com)  
[sales@spinner.eu.com](mailto:sales@spinner.eu.com)



## Compact dimensions

By means of an innovative guideway cover concept the required floor space is up to 30% lower than for similar machines of the same working area.

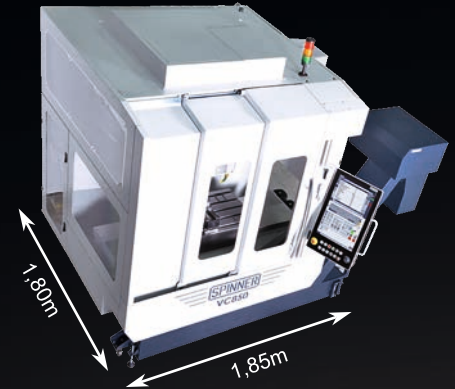

## Optimal chip disposal

There are two additional worm conveyors for automatic chip delivery to the chip conveyor at the front of the machine.

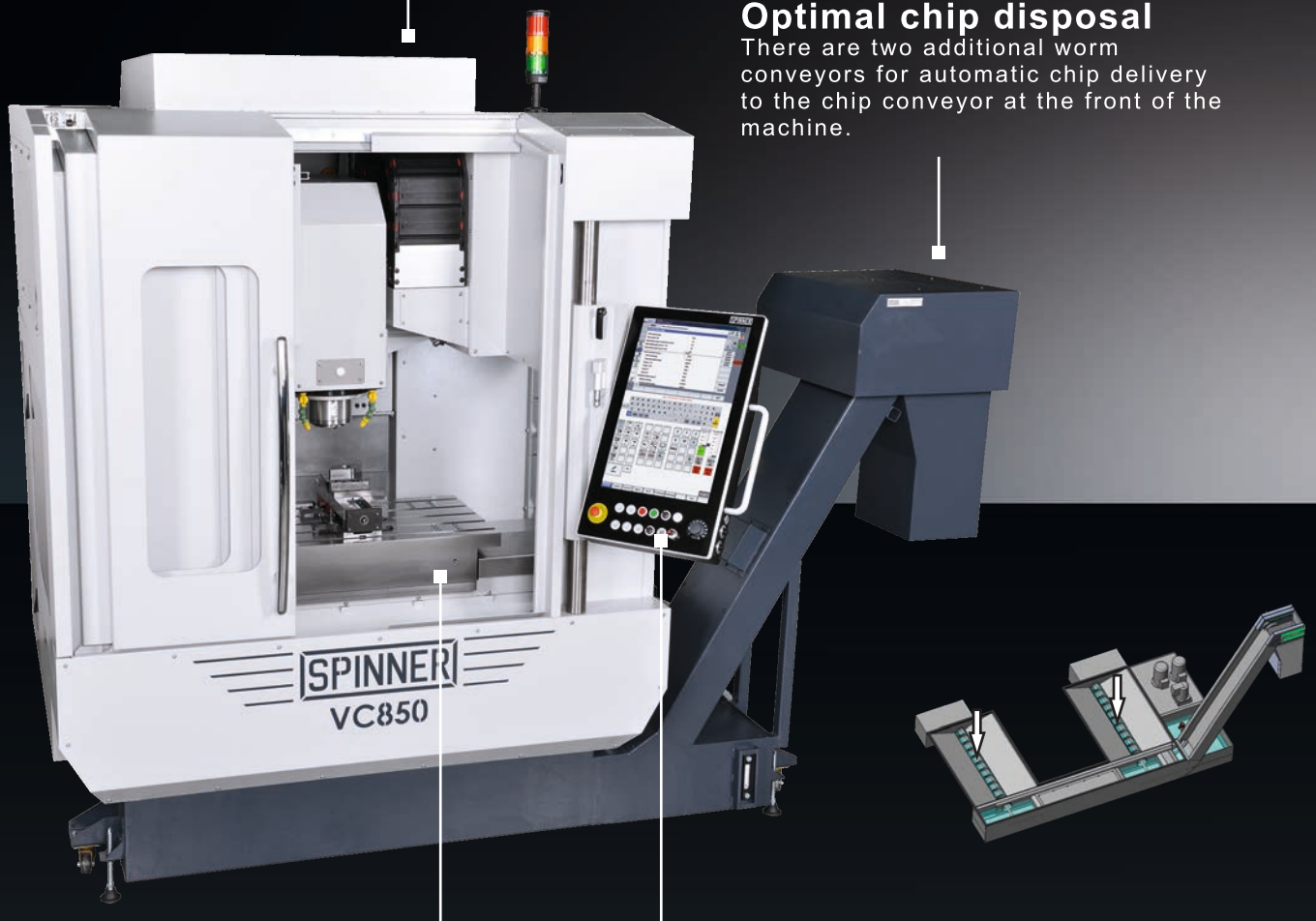

## Ergonomic operating panel

For optimal operating comfort not only the height, but also the angle of the operating panel can be adapted to the operator. In addition, the control panel can be swivelled.



## Small distance to the working table

The distance between the operator and the working table is only 160mm. This facilitates the easy loading.

Powerful  
Dynamic  
Ergonomic  
Compact  
Made in Europe

## High spindle speeds

12.000 rpm  
18.000 rpm

## Large tool magazine

32 or optionally 48 tools are available.

## Cast structure

A heavy cast structure optimised by the FEM method ensures high rigidity and high cutting performance.

## Patented guideway cover concept

With respectively only one wiper in X/Y for best guideway protection and easy maintenance instead of vulnerable cover elements.

## Large ballscrews

All ballscrews are supported on both sides.

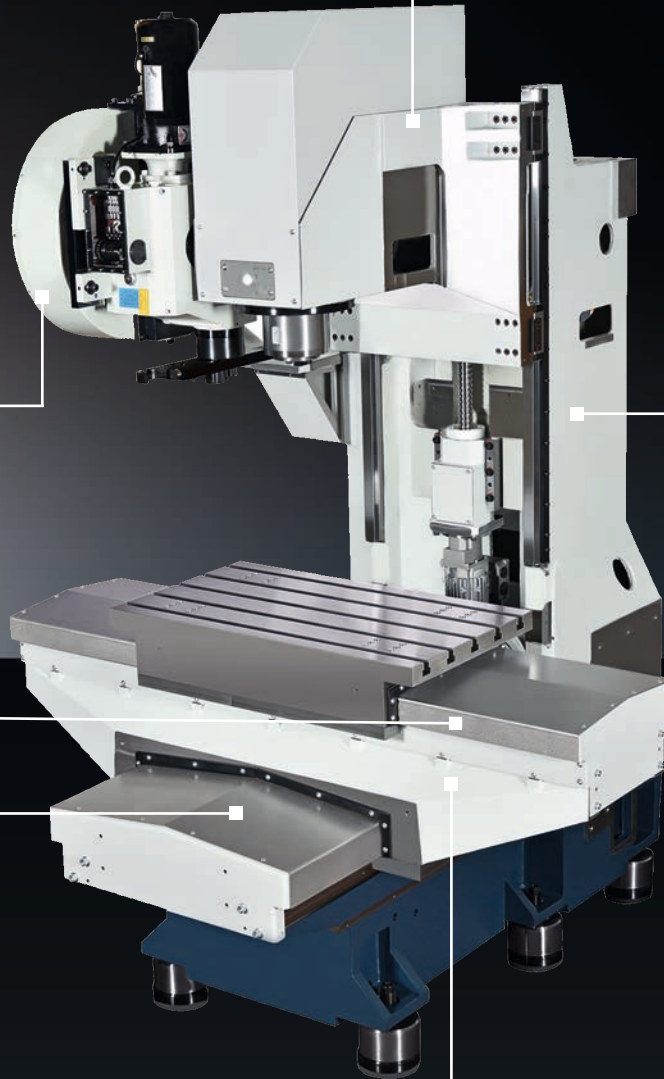

Working area		
X axis	850 mm	
Y axis	510 mm	
Z axis	510 mm	
Min. distance spindle nose - table	120 mm	
Max. distance spindle nose - table	630 mm	
Machining table		
Table dimensions	900 x 510 mm	
Max. table load	500 kg	
T slots	6x 18H7	
Axes		
Feed / Rapid traverse	40 m/min	
Spindle		
Max. spindle speed	12.000 rpm	18.000 rpm
Tool taper	SK40	HSK63
Performance	18,2/10,9 kW (max/S1)	18/10,6 kW (max/S1)
Torque	86/52 Nm (max/S1)	57/34 Nm (max/S1)
Tool magazine		
Number of tool stations	32 +1 (optional 48 +1)	
Max. tool diameter	75 mm	
In case of free adjacent tool stations	125 mm	75 mm
Max. tool length	300 mm	
Max. tool weight	7 kg	
General indications		
Dimensions (L x W x H) <sup>1)</sup>	1850 x 1800 x 2420 mm	
Weight <sup>2)</sup>	approx. 4.500 kg	

1) See floorplan; 2) Without options, Without chip conveyor

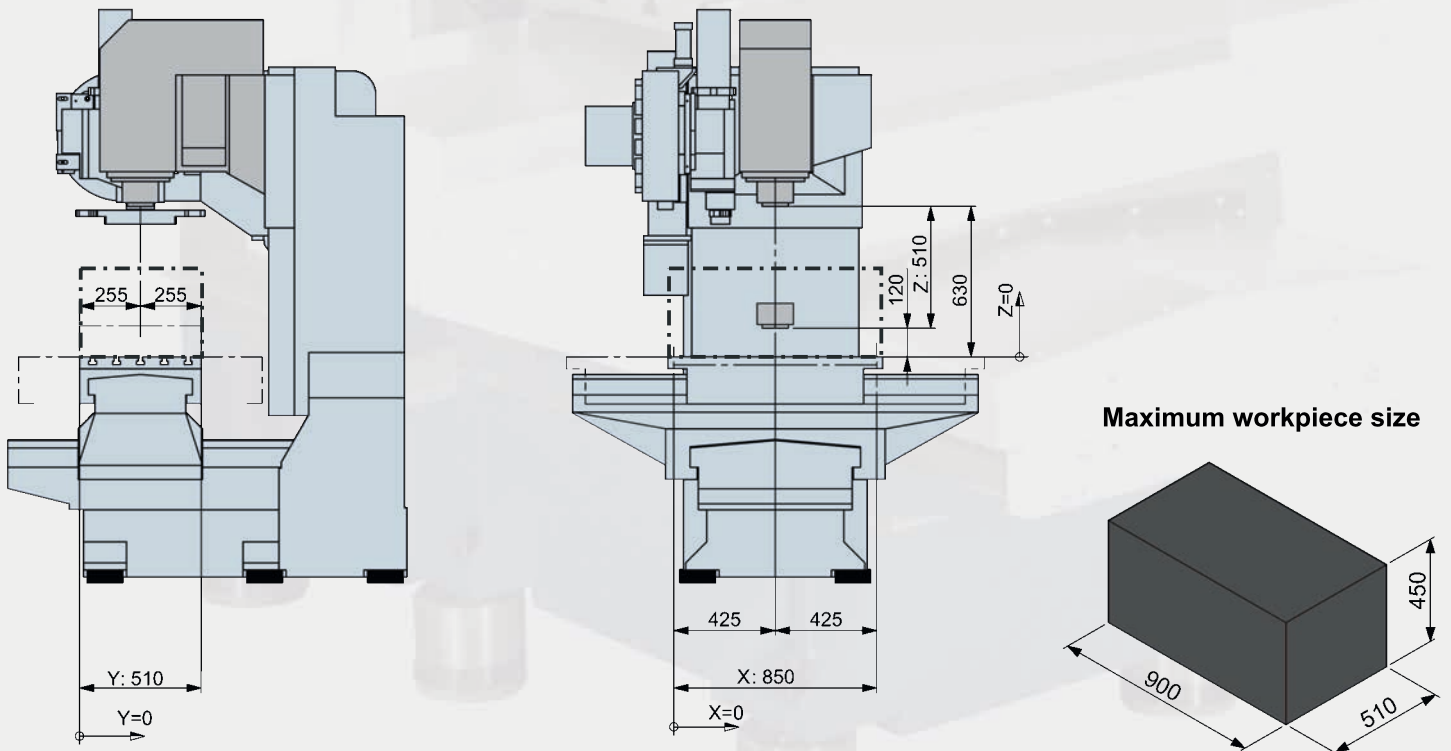

12.000 rpm

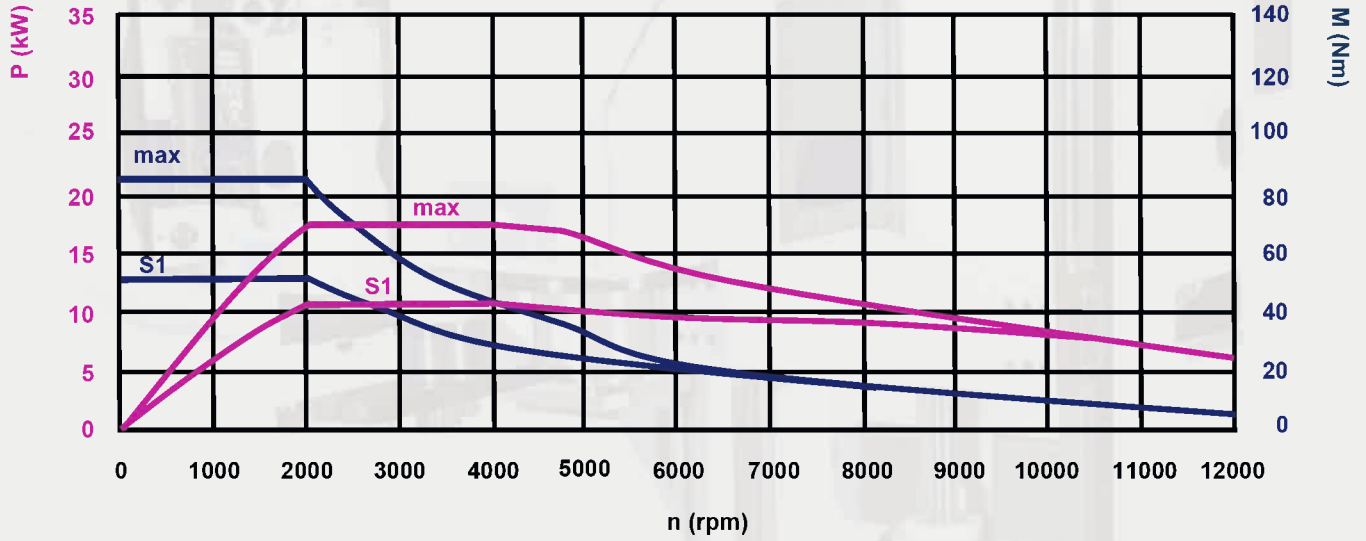

18.000 rpm

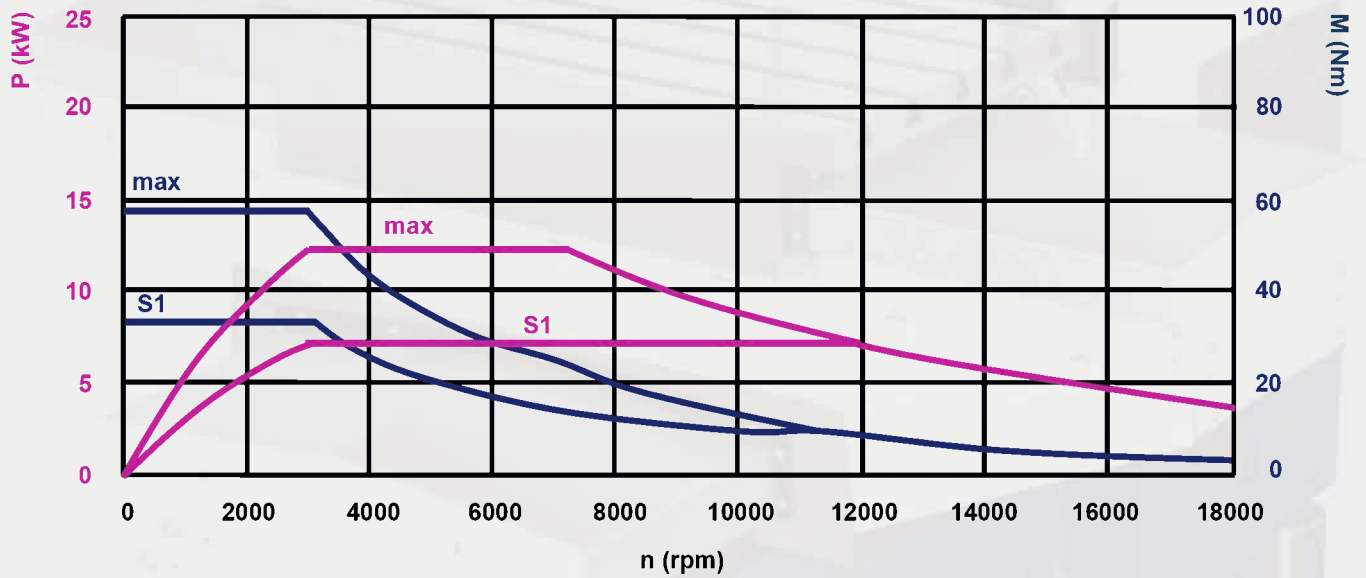



Other options on demand

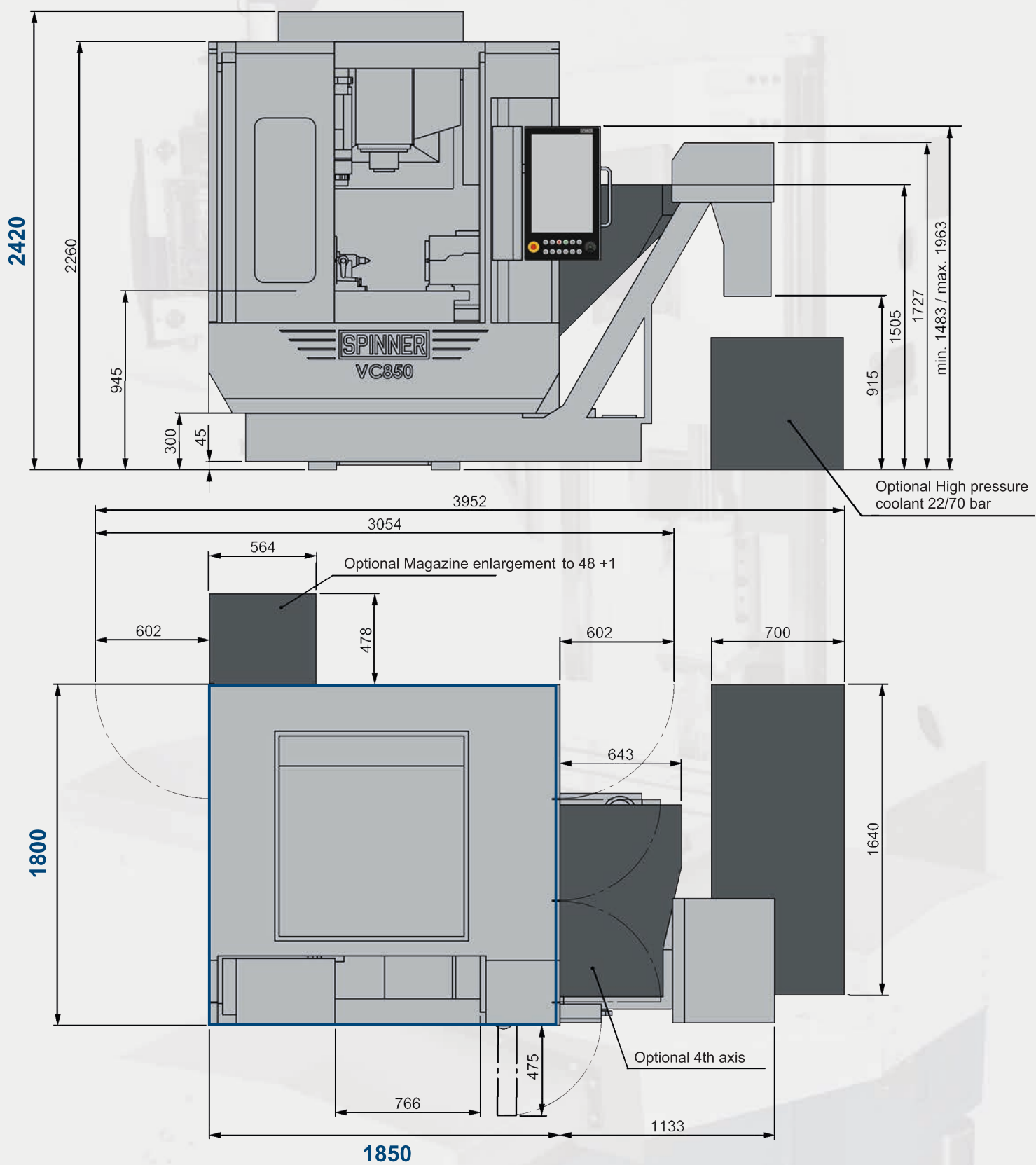

Compact dimensions for low space requirement

Option



Werkzeugmaschinenfabrik GmbH



Spinner Machine-Tools are working successfully world wide with many well known clients in more than 60 countries on 6 continents. We have been fortunate enough to attract small component suppliers in addition to well known global groups in all metal machining industries.

We have designed and produced the most modern machine-tools since 1950. More than 20.000 delivered machines demonstrate their high efficiency, precision and reliability, everyday.

Although Spinner is a medium-sized enterprise we produce and sell more than 1.000 CNC machines a year. And the number is increasing every year. Our company combines the know-how of a global player with the flexibility and cost-effective structures of a family owned business.

Place your trust in our products as well and let us know what we can do for you.



Video

SPINNER Werkzeugmaschinenfabrik GmbH

Rudolf-Diesel-Ring 24

82054 Sauerlach

Tel. +49 (0) 8104 803-0

Fax +49 (0) 8104 803-19

sales@spinner.eu.com



Version 1.8.2019 (GB)

Technical changes of specifications and pictures are subject to change without notice - Pictures can include options, accessories